



Product sheet
ComDry M160L
Desiccant dehumidifier



- Compact
- Lightweight
- Humidity temp sensor
- Air cooled condenser
- Wall bracket
- Reliable
- Energy efficient
- kWh counter
- Remote control option
- Munters Connected Climate® (MCC)



ComDry M160L

The ComDry series is a range of desiccant dehumidifiers with high drying capacity, reliability and low energy consumption. The solid casing is excellent at withstanding corrosion and the dehumidifiers robustness makes it very versatile in a wide range of applications. They are also easy to stack and transport.

Munters ComDry series is particularly suited to water and fire damage restoration operations as well as archives, waterworks and the construction industry. ComDry units can also be used to reduce the relative humidity in storage rooms, cellars, archives and other limited spaces.

The ComDry M160L is designed for fixed installations in closed rooms, unheated basements or where it is impossible to get the wet air outside the building. The air-cooled condenser cools the wet reactivation air below its dew point with help of ambient air. The resulting water droplets are collected in a drip tray and drained away. Operational remote control and/or signals facilitate operation making Munters ComDry M160L the perfect choice for static preservation applications.

MCC is an option to monitor and control ComDry M160L from a WEB service.

All Munters dehumidifiers are based on the rotor technology specially developed by Munters which provides high moisture-absorbing capacity. The flexible design and good performance of the rotor mean that there are almost no limits to its areas of use.



ComDry M160L

Dimensions

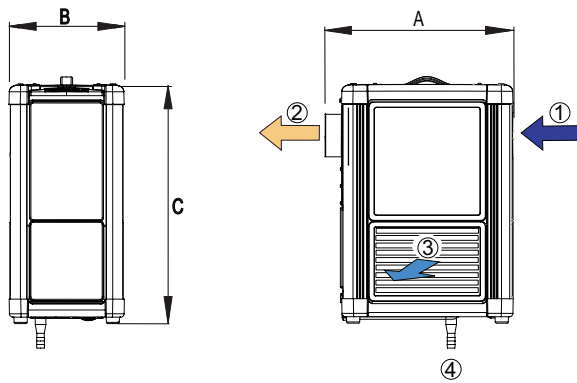

1. Process air in 2. Dry air out 3. Cooling air 4. Drain outlet

Width A	Depth B	Height C	Dry air out	Weight	Drain hose
445mm	270mm	555mm	100mm	17kg	d=12.5mm

Diagram measurements are for reference only.
Scaled and dimensioned drawings are available from Munters.

- Robust aluminium / plastic casing
- Air cooled condenser
- Wall bracket
- Humidity control
- Multifunction control displaying RH (%), X (g/kg) or Dp (°C)
- Resetable kWh and hour counter
- Socket for external sensor
- Filter change without tools
- 2.75m rubber cable
- Modulating heater

Options

- External sensor
- External signal box
 - Remote on/off
 - Operation
 - Alarm
- Remote control via external control panel
- Ducted air inlet
- Munters Connected Climate® (MCC)

Technical specifications

Dry Air		
Maximum airflow	160	m ³ /h
Rated airflow at 40Pa	150	m ³ /h
Maximum static pressure	225	Pa
Total Power, Voltage & Current		
Total power	1.01	kW
Heater power	0.84	kW
230V 1-50/60Hz	4.4	A
115V 1-50/60Hz	8.8	A
Miscellaneous Data		
Operating temperature	0/+30	°C
IEC protective class	33	unit IP
IEC Protective class, control board	54	IP
Filter class	G3	-
Max noise level	58	dB(A)

Dehumidification Capacity

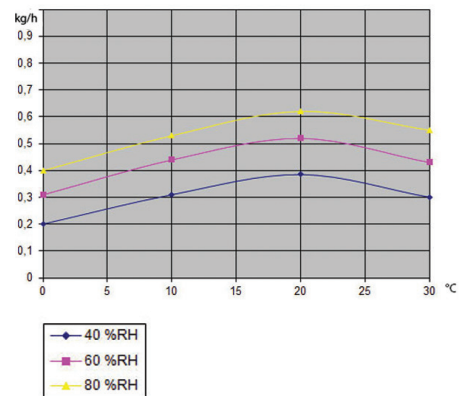

This may not, depending on conditions, correspond to actual drained water volume.

For more
information visit
munters.com



Australia Phone +61 2 8843 1588, dh.info@munters.com.au **Austria** Phone +43 1 6164298-92-51, lufentfeuchtung@munters.at **Belgium** Phone +32 1528 5611, info@muntersbelgium.be **Brazil** Phone +55 41 3317 5050, munters@com.br **Canada** Phone +1 905 564 6466, dhinfo@munters.com **China** Phone +86 10 8048 3493, info@munters.com.cn **Czech Republic** Phone +420 775 569 657, info@munters-odvlhcovani.cz **Denmark** Phone +45 4495 3355, info@munters.dk **Finland** Phone +358 20 776 8230, laitemyynti@munters.fi **France** Phone +33 1 3411 5757, dh@munters.fr **Germany** Phone +49 4087 96900, mgd@munters.de **India** Phone +91 20 668 18 900, info@munters.in **Italy** Phone +39 0183 52 11, marketing@munters.it **Japan** Phone +81 3 5970 0021, mkk@munters.co.jp **Korea** +82 2761 8701, munters@munters.co.kr **Mexico** Phone +52 81 8262 5400, munters@munters.com.mx **Netherlands** Phone +31 172 433231, vochtbeheersing@munters.nl **Poland** Phone +48 58305 3517, dh@munters.pl **Singapore** Phone +65 6744 6828, info@munters.com.sg **South Africa** Phone +27 11 971 9700, info@munters.co.za **Spain** Phone +34 91 640 09 02, marketing@munters.es **Sweden** Phone +46 8 626 63 00, avfukning@munters.se **Switzerland** Phone +41 52 343 8886, info.dh@munters.ch **Thailand** Phone +66 2642 2670, info@munters.co.th **Turkey** Phone +90 262 751 3750, info@muntersform.com **UAE** +971 4 8809295, middle.east@munters.com **United Kingdom** Phone +44 1480 432 243, dryair@munters.co.uk **USA** Phone +1 978 241 1100, dhinfo@munters.com **Vietnam** Phone +84 8 8256 838, vietnam@muntersasia.com

